

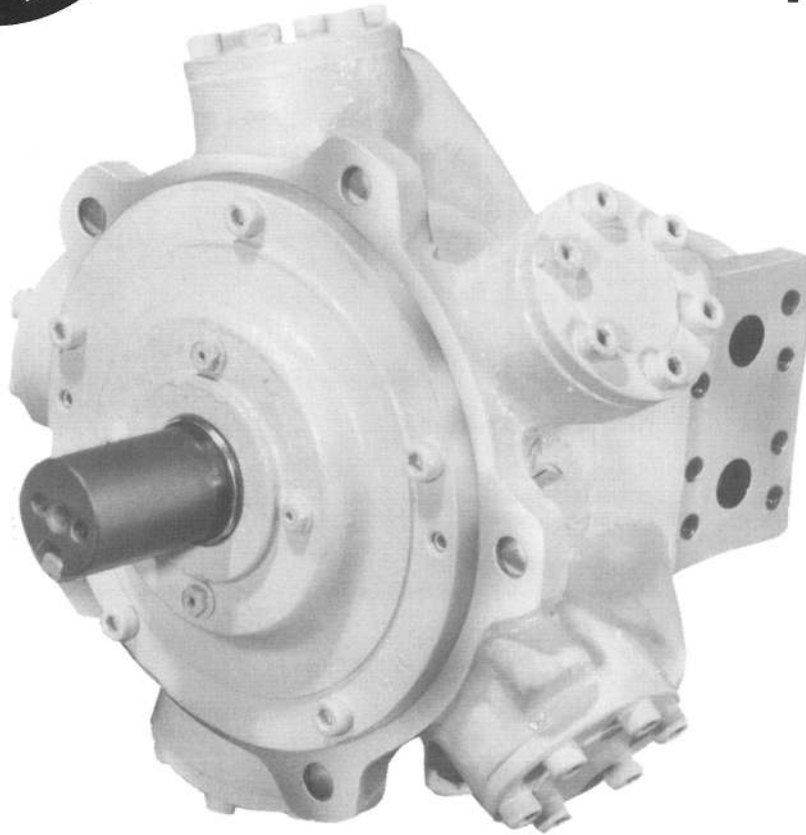

MRH-12

LOW SPEED • HIGH TORQUE
**HYDRAULIC
 MOTOR**



FEATURES

- Speed is infinitely variable and torque constant throughout the speed range.
- Acceleration, deceleration, and reversing are rapid, especially with high inertia loads.
- Precise positioning of driven equipment (such as a crane, winch, or precision conveyor) is possible because of high volumetric efficiency.
- Operation is smooth because torque variation during rotation is limited to an imperceptible value by the piston's overlapping stroke.
- Long life is ensured by hydraulically balancing essential bearing surfaces.
- Low speed operation reduces wear and eliminates gear reductions.
- Installation cost is lowered and piping simplified because of three separate drain port locations.

SPECIFICATIONS

Displacement volume	12.7 IN. ³ /REV.
Maximum continuous pressure	3570 PSI
Intermittent peak pressure	4000 PSI
Maximum continuous back pressure	350 PSI
Maximum intermittent back pressure	1000 PSI
Maximum continuous output torque	535 FT.-LBS.
Starting torque at 3570 PSI	467 FT.-LBS.
Maximum continuous speed	600 RPM
Maximum continuous power	42 HP
Moment of inertia (GD ²)	50 LB.-IN. ²
Maximum fluid temperature	175°F
Dry weight	81 LBS.

HYDROSTAR® has been specializing in The design of low-speed high-torque motors since 1961. Today's heavy duty hydraulic motors are the most practical choice for applications demanding speeds as low as 1 rpm because they eliminate the need for gear boxes. Sizes range from 12 cu. in./rev. to 540 cu. in./rev., up to 20,000 ft. lbs., all without a gear box reducer.

Models are available for most every machinery application, including construction, cargo, marine, mining, steel manufacturing and other industrial uses. Rely on HYDROSTAR® FOR PERFORMANCE, DURABILITY AND LOW MAINTENANCE.

Graph 1

MRH-12 Performance Curve

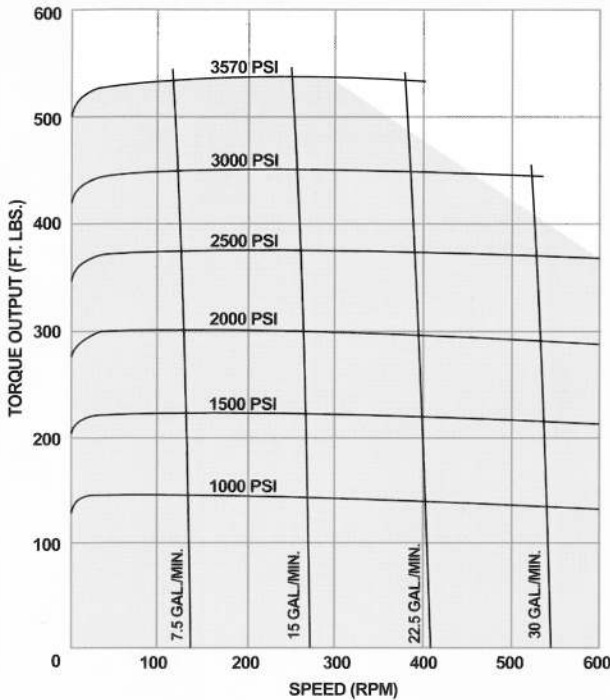

Oil and Filtration

Because the oil not only transfers the force but also lubricates mating parts of the motor, care must be taken to assure minimum fluid viscosity is 120 SUS. However, it is recommended for continuous operation to maintain the viscosity between 165 and 345. Maximum operating temperature should be less than 175°F.

Even when the proper oil is used, wear will accelerate as oil becomes contaminated. Hydraulic fluid life depends on conditions under which it is used and only experience can determine precise intervals at which fluids should be changed. With mineral oils it is recommended that samples be taken at about 1000 hour intervals and sent to the manufacturer for analysis. This will help determine the best timing for fluid changes.

Filtration recommendation is 25 micron. Since pumps are more critical to contamination, it is advisable to investigate what filtration will be required to sustain the life of the pump.

Minimum Operating Speed

Minimum operating speed of 3 rpm is possible depending on load characteristics, but smooth performance of 5 rpm is normal. Starting torque varies with crankshaft angle. A reduction in torque occurs if the back pressure is excessive, but viscosity effects are negligible.

Bearing B10-LIFE

Bearing B10-LIFE of taper roller bearings used in HYDROSTAR® motors is explained in Graph 2 below. Bearing B10-LIFE is the number of hours at which 10%

of the bearings may be expected to show some evidence of wear. The other 90% will be satisfactory. In fact, the average life of the bearings is 4 times the B10-LIFE.

Graph 2

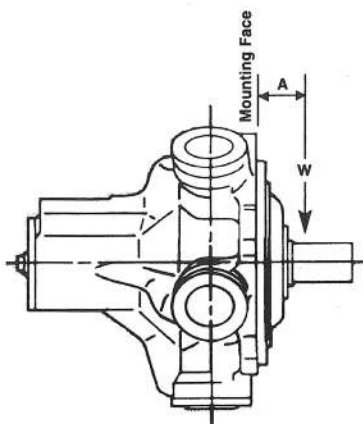
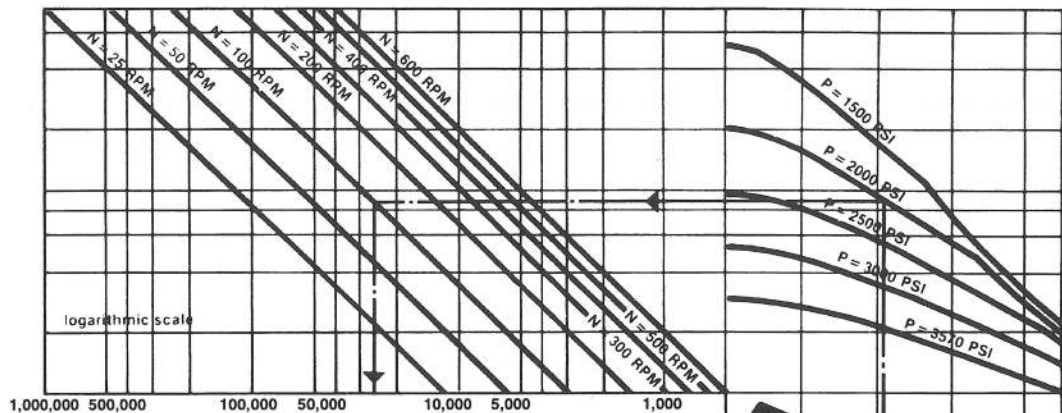

Example of use (See chain dotted line)

GIVEN

- Side load W = 2500 LBS.
- Distance from mounting face A = 2 IN.
- Pressure P = 2000 PSI
- Speed N = 100 RPM

ANSWER

Estimated Bearing B10-LIFE = 27,000 HOURS

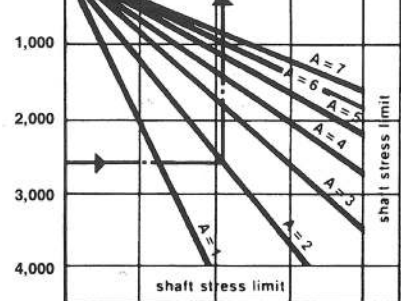

Principal of Operation

The HYDROSTAR® motor consists of 5 cylinders. Hydraulic pressure to each cylinder is distributed by a rotary valve which rotates in conjunction with a crankshaft supplying hydraulic pressure to the power stroke of the cylinders. The hydraulic pressure to the cylinder exerts a force onto the piston as shown in the drawing below. The force is transmitted to the ball end of a connecting rod. This force on the connecting rod is relayed to the surface area of the cam, thus providing the rotary movement. At least two cylinders are always subject to pressurized fluid to offer smooth rotation.

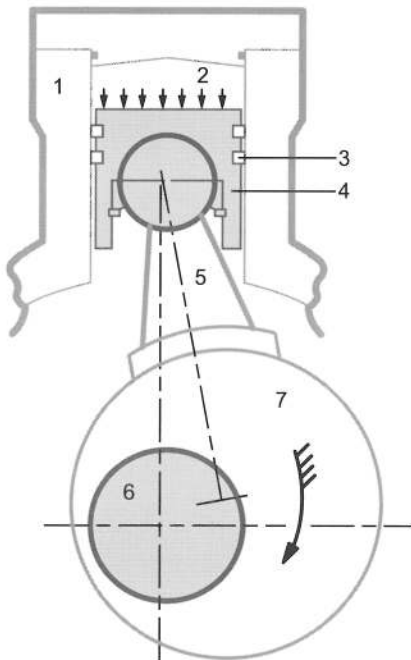

1. Cylinder
2. Hydraulic Pressure
3. Piston Ring
4. Piston
5. Connecting Rod
6. Shaft
7. Cam

Graph 3

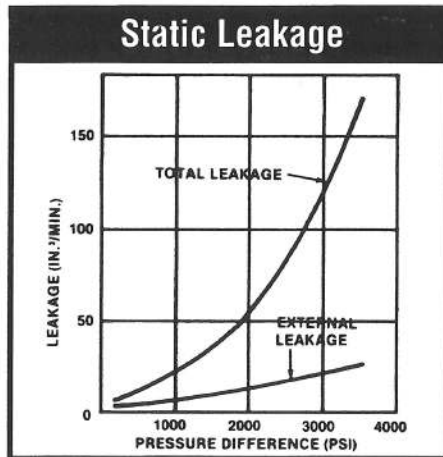

Total static leakage is: internal leakage & external leakage. Total static leakage is used when the outlet port is blocked and the torque load attempts to rotate the shaft as in winch applications. Values given will be considerably greater unless sufficient inlet pressure is maintained. The creep speed can be calculated from the following formula:

$$\text{Creep Speed (RPM)} = \frac{\text{Total static Leakage (IN.}^3\text{/MIN.)}}{12.7 \text{ (IN.}^3\text{/REV.)}}$$

Graph 5

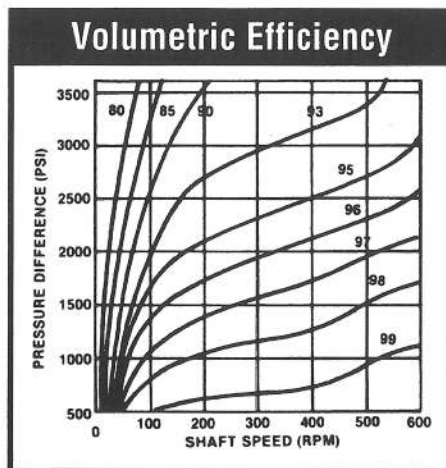

Input flow required to attain any given speed and pressure can be calculated from the graph using the nominal motor displacement of 12.7 cu. in./rev.

$$\text{Input Flow (IN.}^3\text{/MIN.)} = \frac{12.7 \text{ (IN.}^3\text{/REV.)} \times \text{Motor Speed (RPM)} \times 100}{\text{Motor Volumetric Efficiency (\%)}}$$

1 GAL./MIN. = 231 IN.³/MIN.

Graph 4

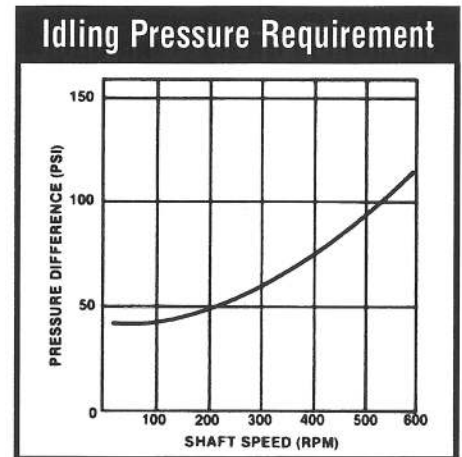

Graph 4 indicates pressure difference required to idle the motor at various speeds and no output torque. Values will be slightly greater at higher viscosities. Caution should be taken to assure sufficient inlet pressure is maintained to prevent cavitation when the motor operates as a pump or when the load overruns the motor.

Sufficient back pressure should be maintained to counteract centrifugal forces in the motor. Back or boost pressure is the pressure present at the low pressure port of the motor. These minimum pressures can be calculated as follows:

$$\text{Boost or Back Pressure (PSI)} = \frac{1}{2} \text{ Idling Pressure (PSI)} + \text{Crankcase Pressure (PSI)}$$

Graph 6

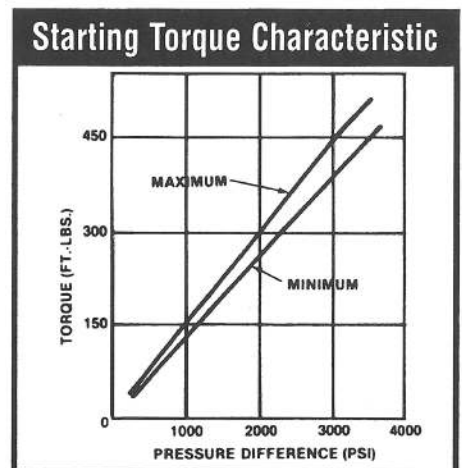

Starting torque varies with the crankshaft angle and maximum and minimum values are shown by the graph. A reduction in torque occurs if back pressure is excessive but viscosity effects are negligible.

Above curves are results obtained on mineral oil of 160-200 SUS viscosity.

MRH-12

INSTALLATION DIMENSIONS

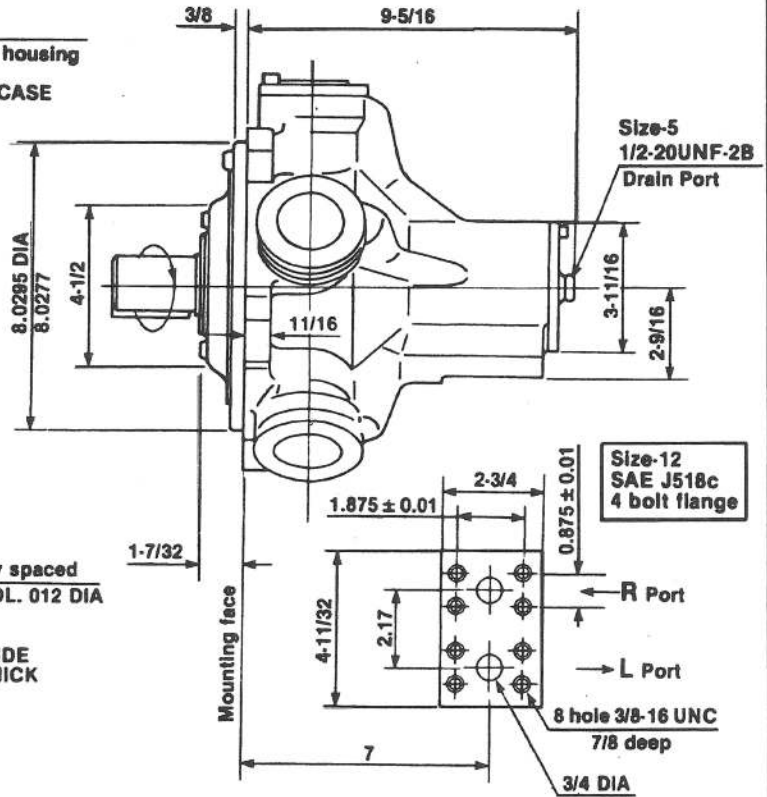
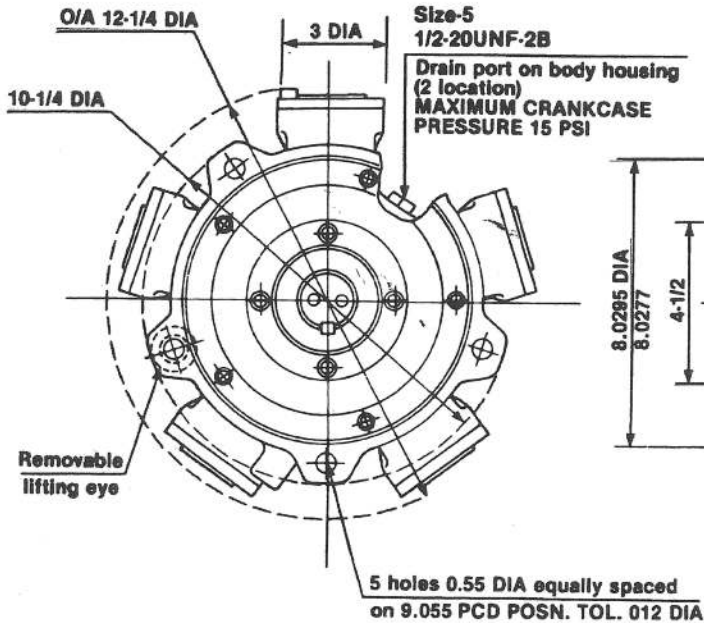

Key—
 0.3949/0.3943 WIDE
 0.3150/0.3135 THICK
 2.128 LONG

